

TECHNICAL RIDER – ZIRKUS GONZO

PERFORMANCE

Zirkus Gonzo is a one-man circus performance of appr. 40 minutes duration. A big part of the show takes place on the trapeze, aerial rope and tissue in a 7,5 meter high rig.

SPACE

Stage: Min. 7m width, 4m depth, 7,5m height. Rigging points Min. 10m width and 12m depth (see illustration)

Stage must be solid and even.

For build up/take down we need access to venue with our van.

Seats for audience should be provided by the organizer.

RIGGING

The rig can be fixed with pegs in the ground or with weights (4 x min. 500kg – provided by the organiser)

If performance is taking place at a venue with good rigging possibilities (e.g. Circus tent) other options may be possible. Please contact Zirkus Gonzo in advance, so we can find the best solution.

BUILD UP

About 4 hours + 1 hour for lights (if necessary). For setting up the rig we need 6 people helping for about 15 minutes. After building up two hours for warm-up, dressing and make-up are required before performing.

Whenever possible, most of the building up should take place a day before the first performance.

TAKE DOWN

About 2 hours. For taking down the rig we need 6 people helping for about 15 minutes

LIGHTING

For evening or indoor performances the organiser should provide lighting (minimum of 5 PC or similar). In consultation with Zirkus Gonzo we can provide a simple lighting if required. Please contact Zirkus Gonzo in advance.

SOUND

Own sound system (we need 220V - 900W).

OTHER

Max two performances per day. Between them should be a break of at least 3 hours.

RIG

FRONT

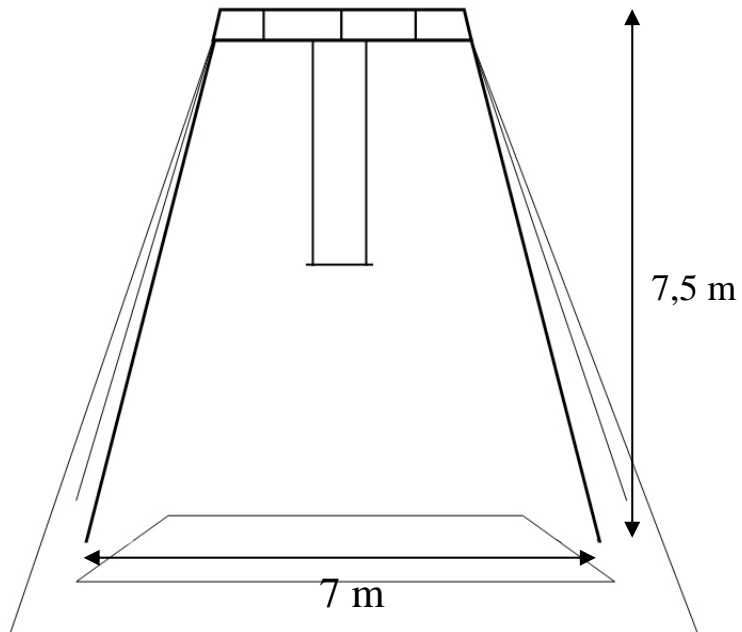

FROM ABOVE

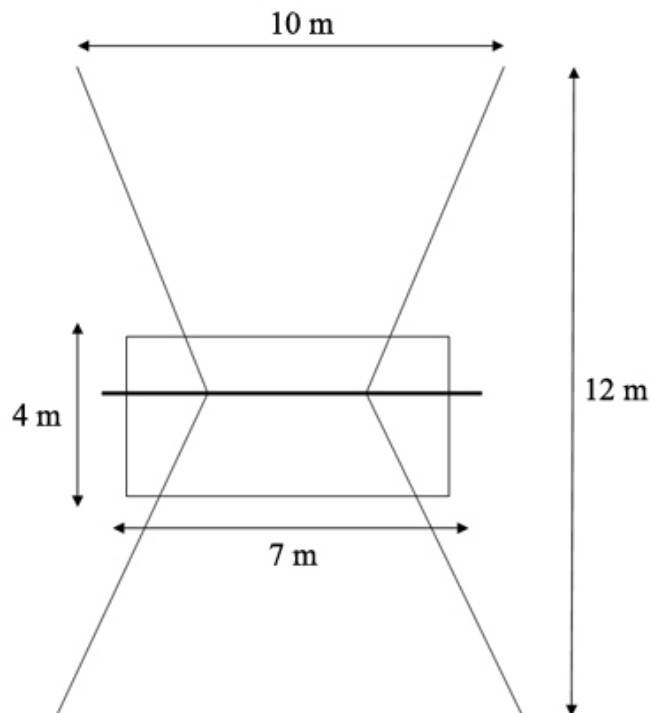

To set up we need 3 meters extra in front of and behind the rig.